

# レール

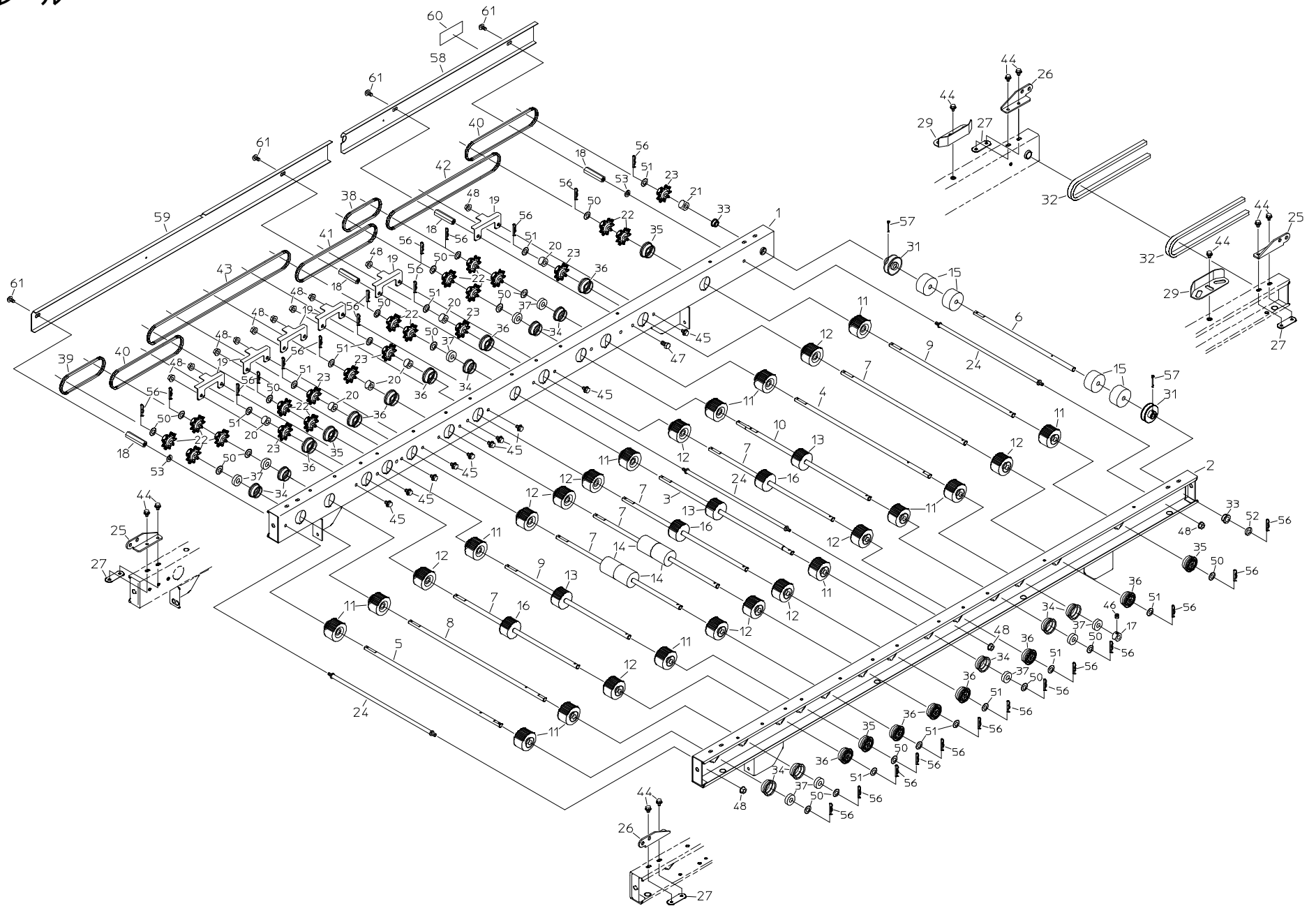

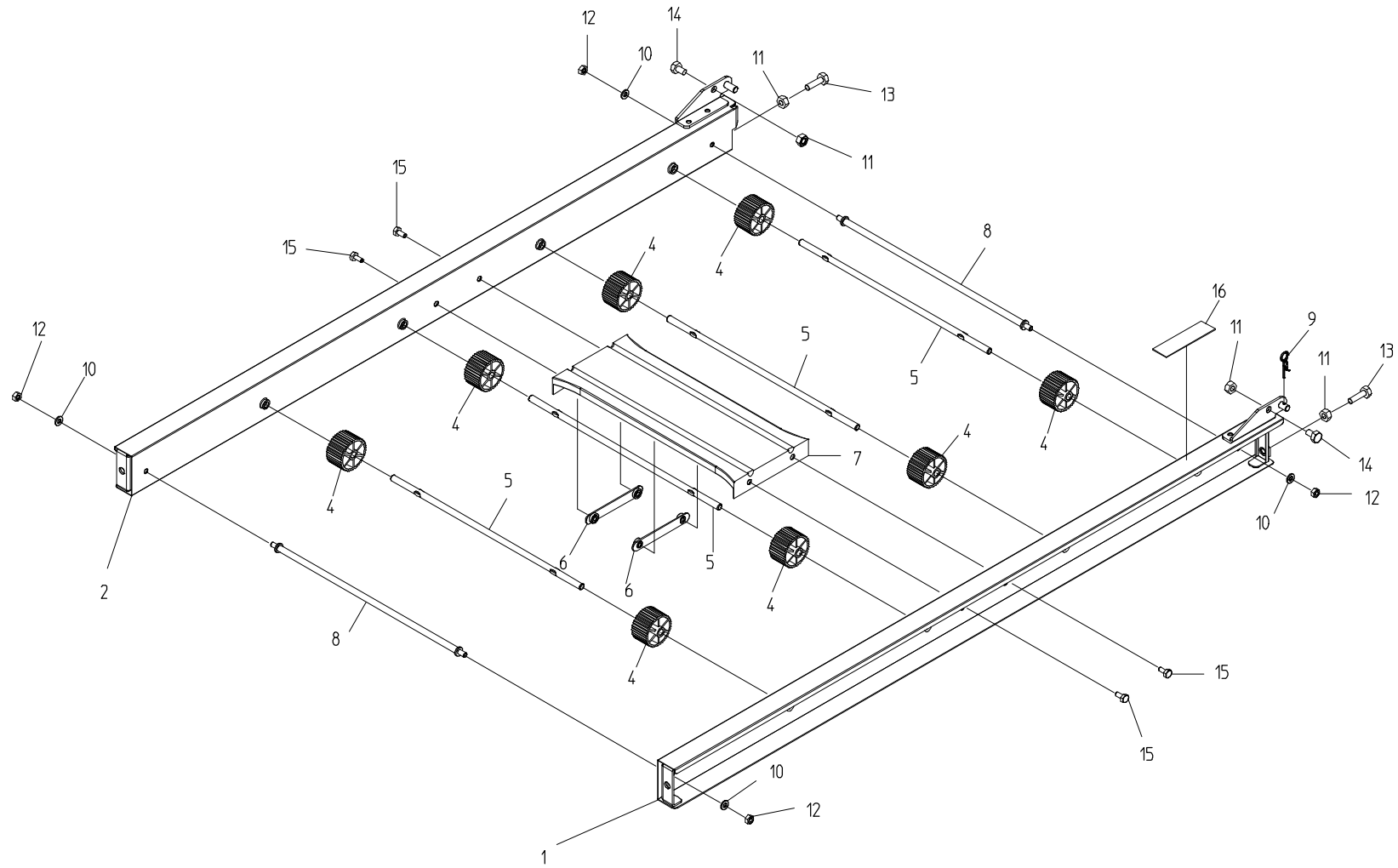

# 補助レール



|  |  |   |  |   |
|--|--|---|--|---|
|  |  |   |  |   |
|  |  |   |  |   |
|  |  | R |  |   |
|  |  |   |  |   |
|  |  |   |  | x |
|  |  |   |  | x |
|  |  |   |  |   |
|  |  |   |  |   |
|  |  | R |  |   |
|  |  |   |  |   |
|  |  |   |  |   |
|  |  |   |  |   |
|  |  |   |  | x |
|  |  |   |  | x |
|  |  |   |  | x |
|  |  |   |  |   |

# 補助レール(P)

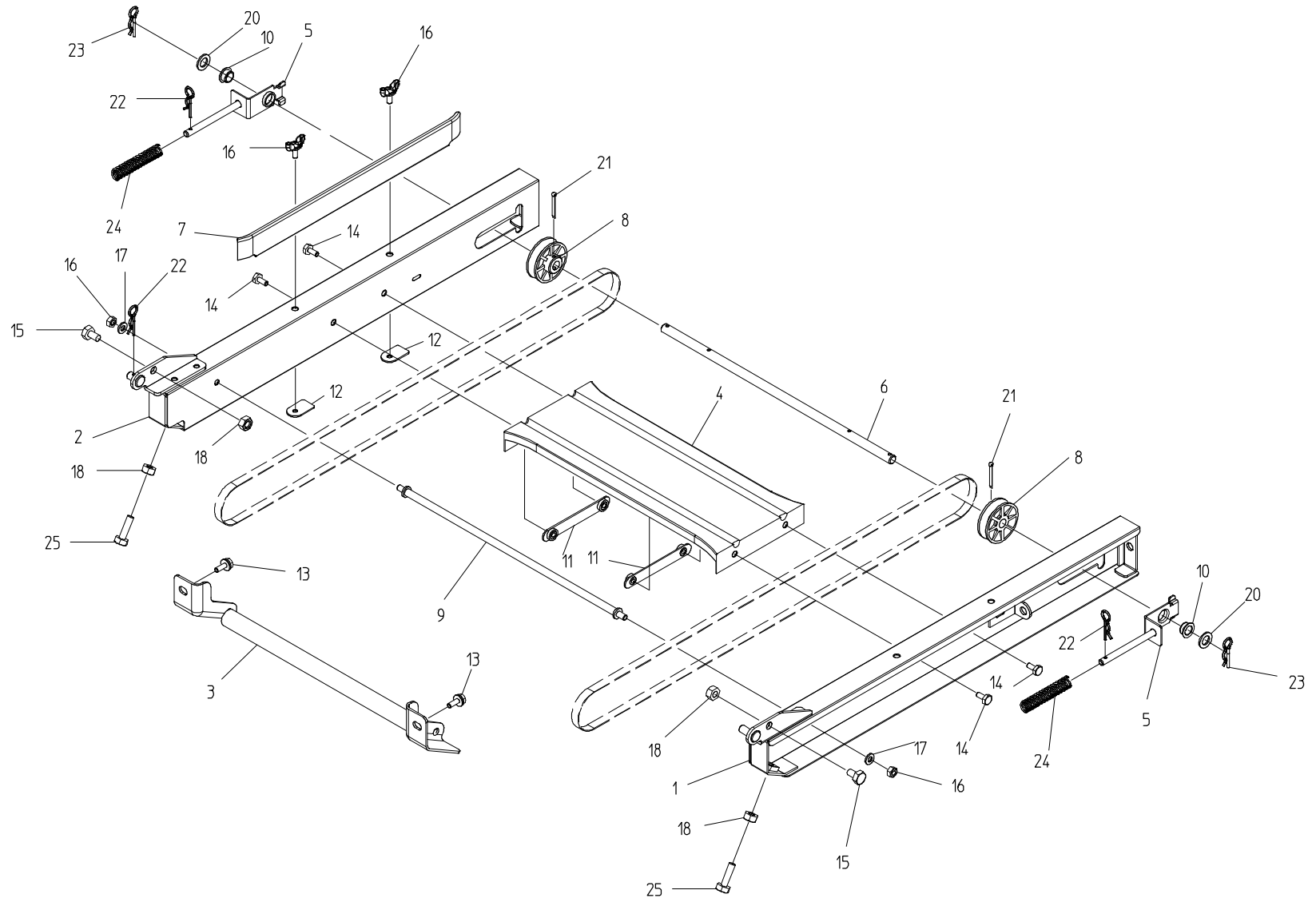

P

|  |  |   |  |   |
|--|--|---|--|---|
|  |  |   |  |   |
|  |  |   |  |   |
|  |  |   |  |   |
|  |  |   |  |   |
|  |  |   |  |   |
|  |  |   |  | x |
|  |  |   |  |   |
|  |  |   |  |   |
|  |  |   |  | x |
|  |  |   |  |   |
|  |  |   |  | x |
|  |  |   |  | x |
|  |  |   |  | x |
|  |  |   |  | x |
|  |  |   |  |   |
|  |  |   |  |   |
|  |  |   |  |   |
|  |  |   |  | x |
|  |  | R |  |   |
|  |  | R |  |   |
|  |  |   |  | x |
|  |  |   |  | x |

脚

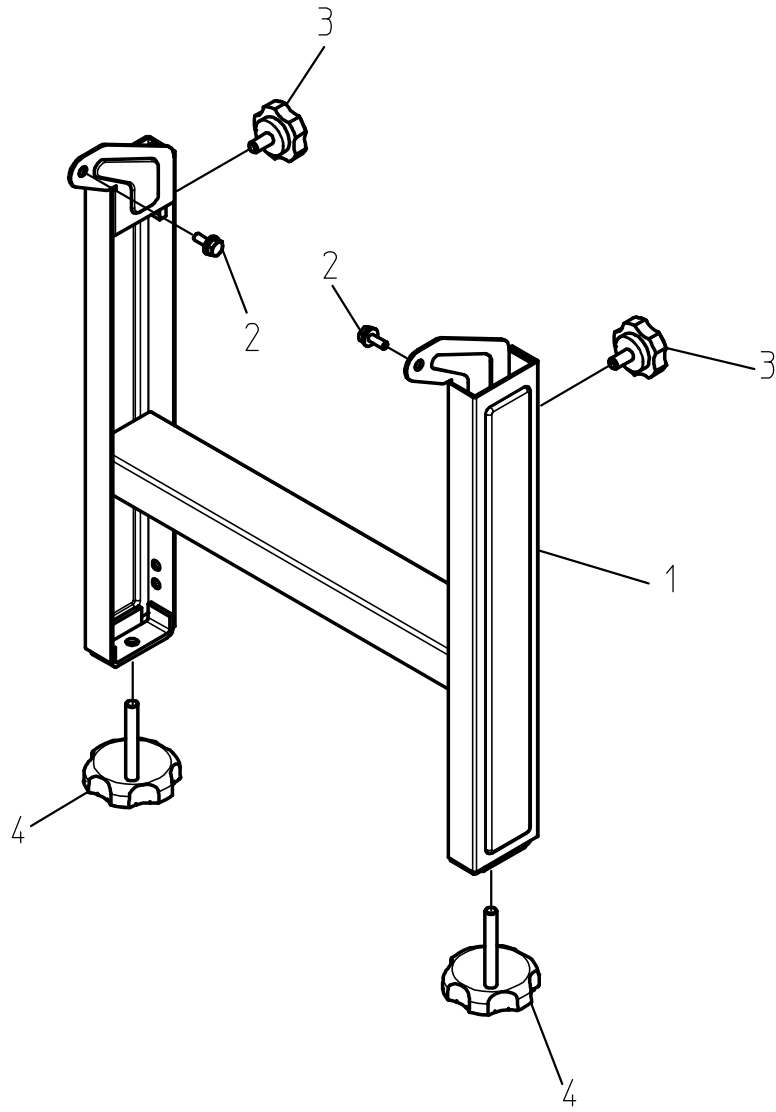

|  |  |   |  |   |
|--|--|---|--|---|
|  |  |   |  |   |
|  |  |   |  |   |
|  |  |   |  | x |
|  |  | x |  | x |
|  |  |   |  | x |



# 搬送駆動部

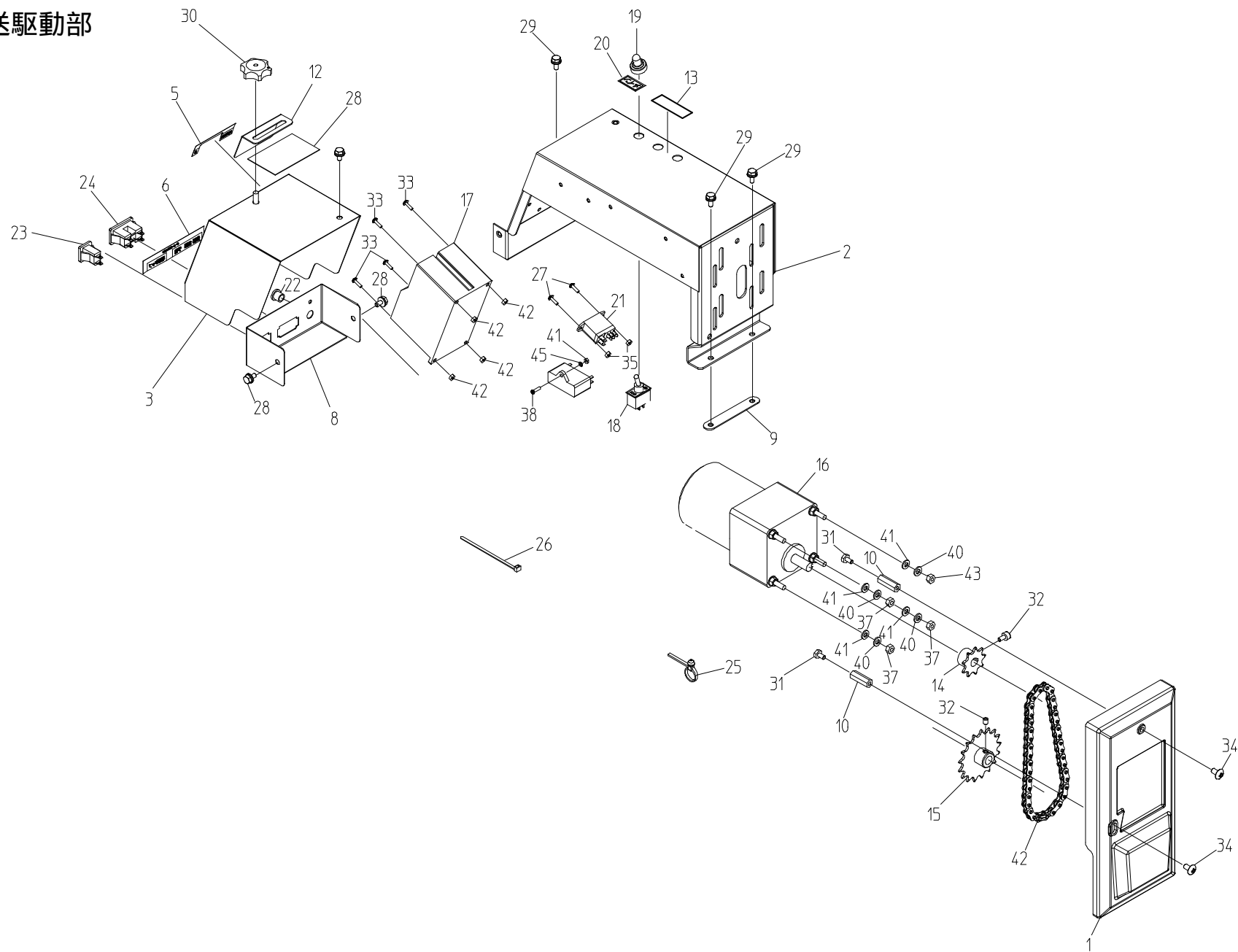







# 回転ブラシ(L)

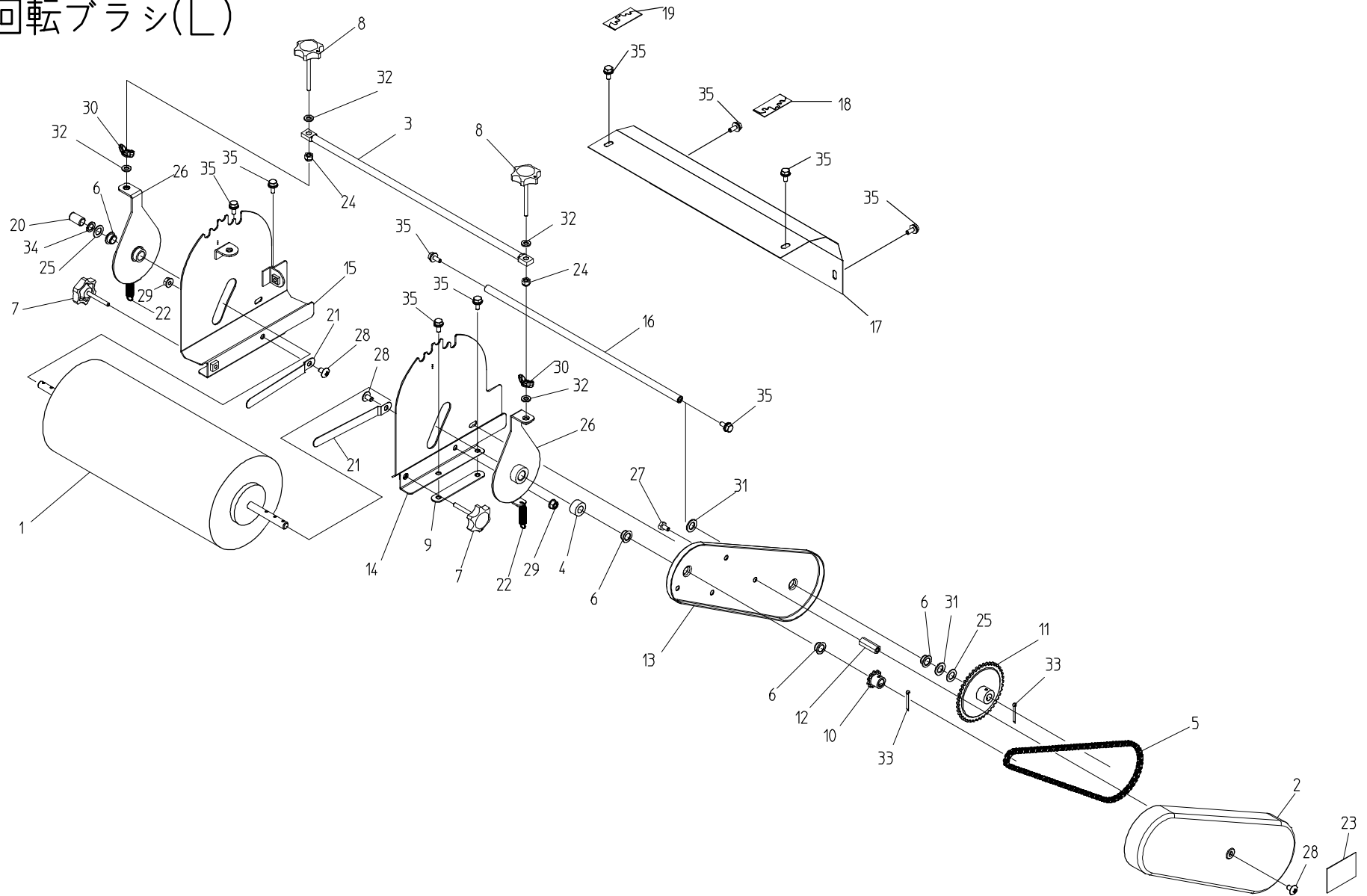

# 回転ブラシ(R)

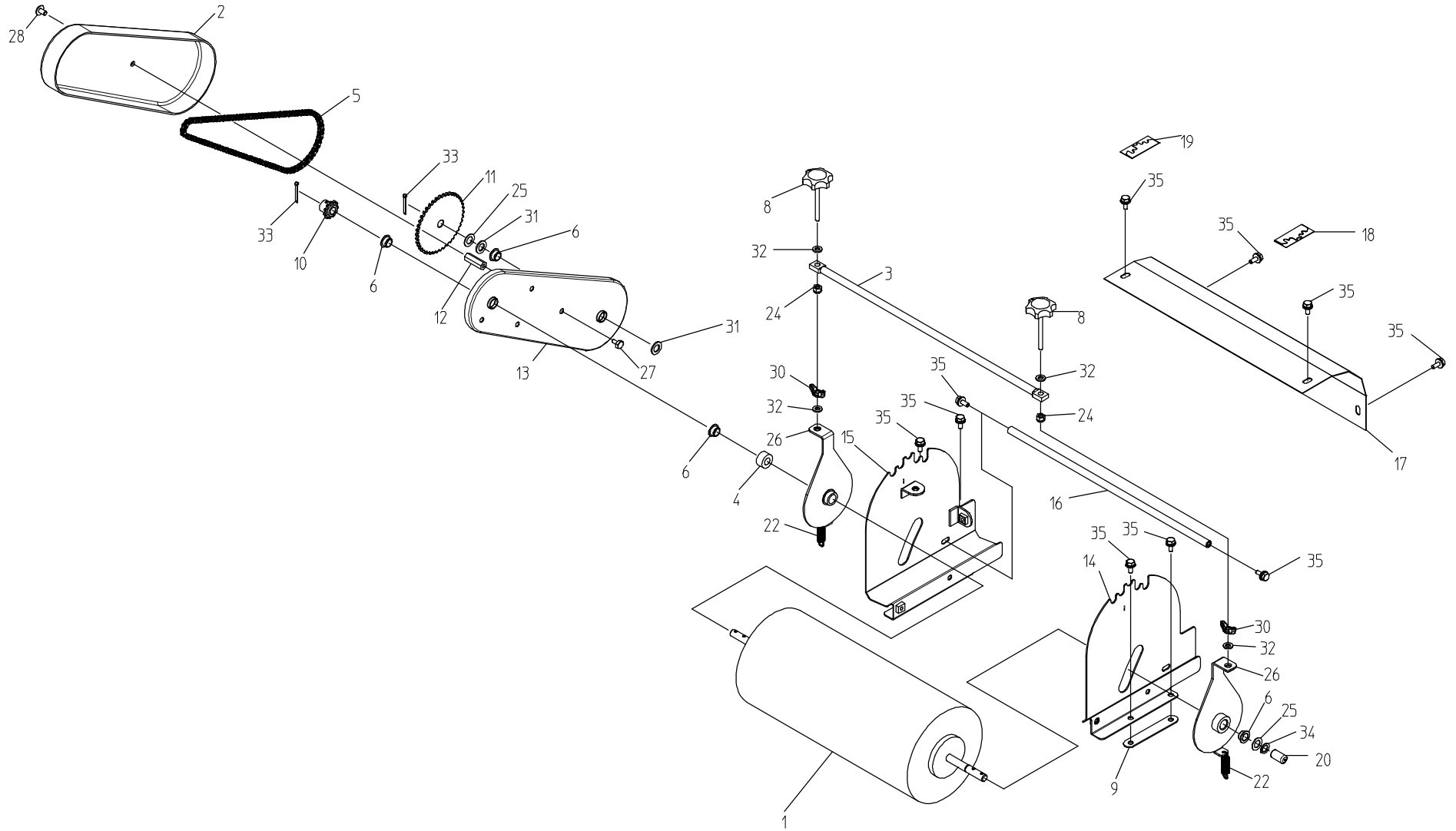



# スミトリ装置

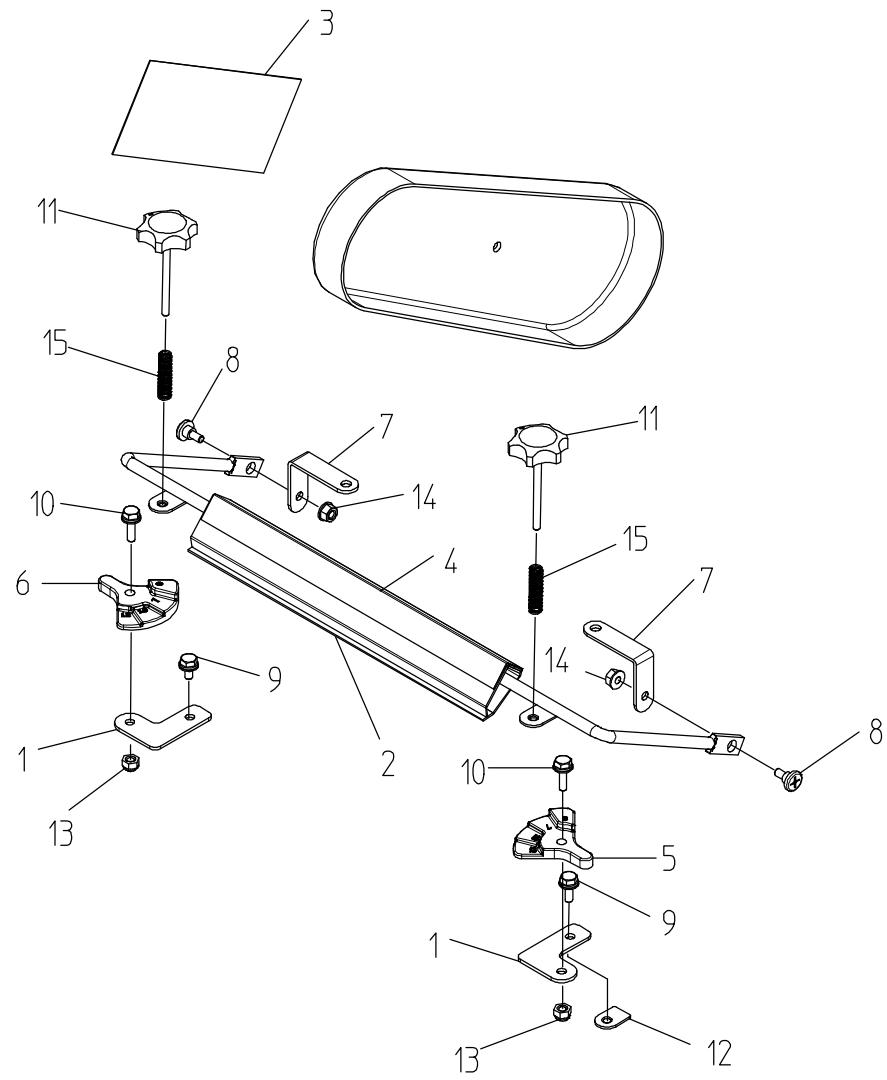





# 土受け

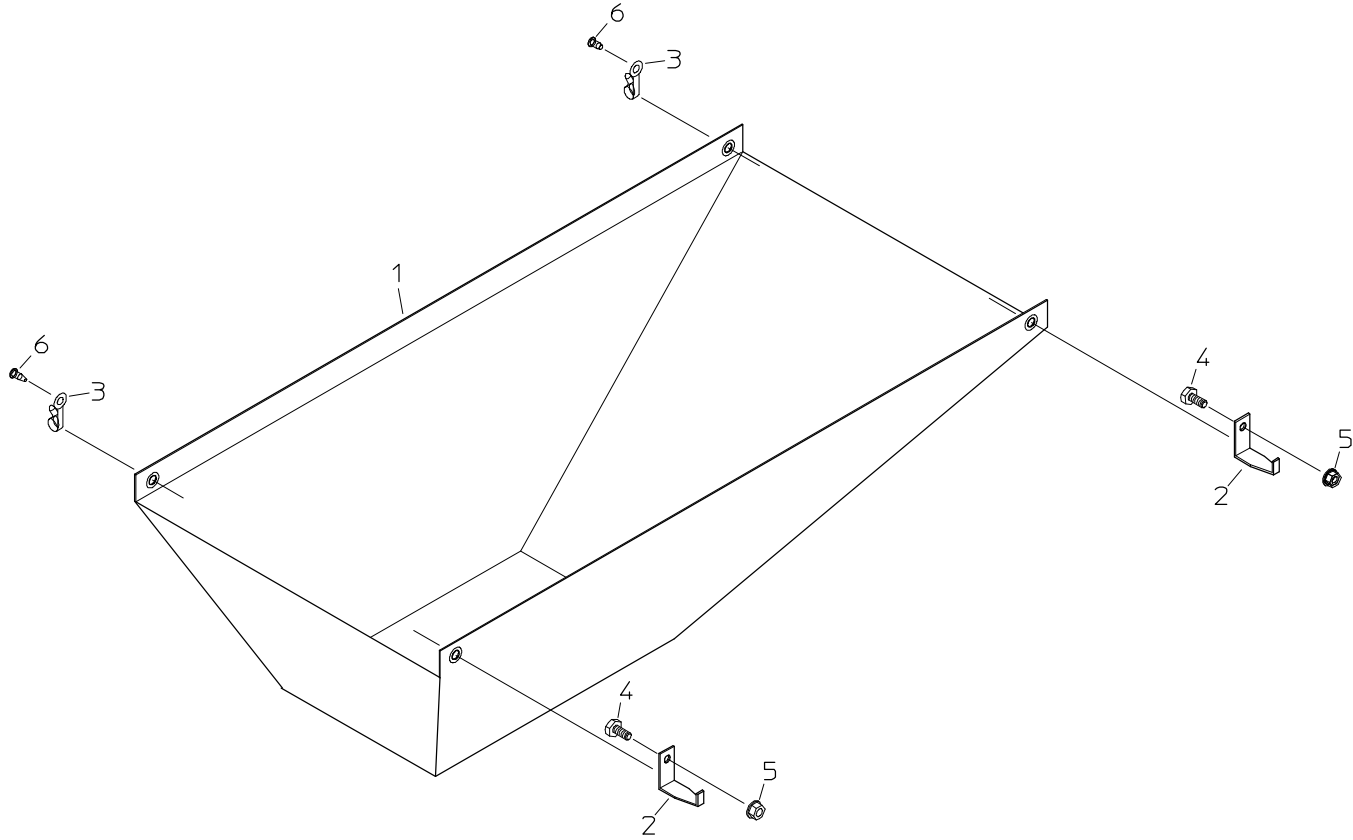

|  |  |   |  |   |
|--|--|---|--|---|
|  |  |   |  |   |
|  |  |   |  |   |
|  |  |   |  |   |
|  |  | R |  |   |
|  |  |   |  | x |
|  |  |   |  |   |
|  |  |   |  |   |

# キャスター

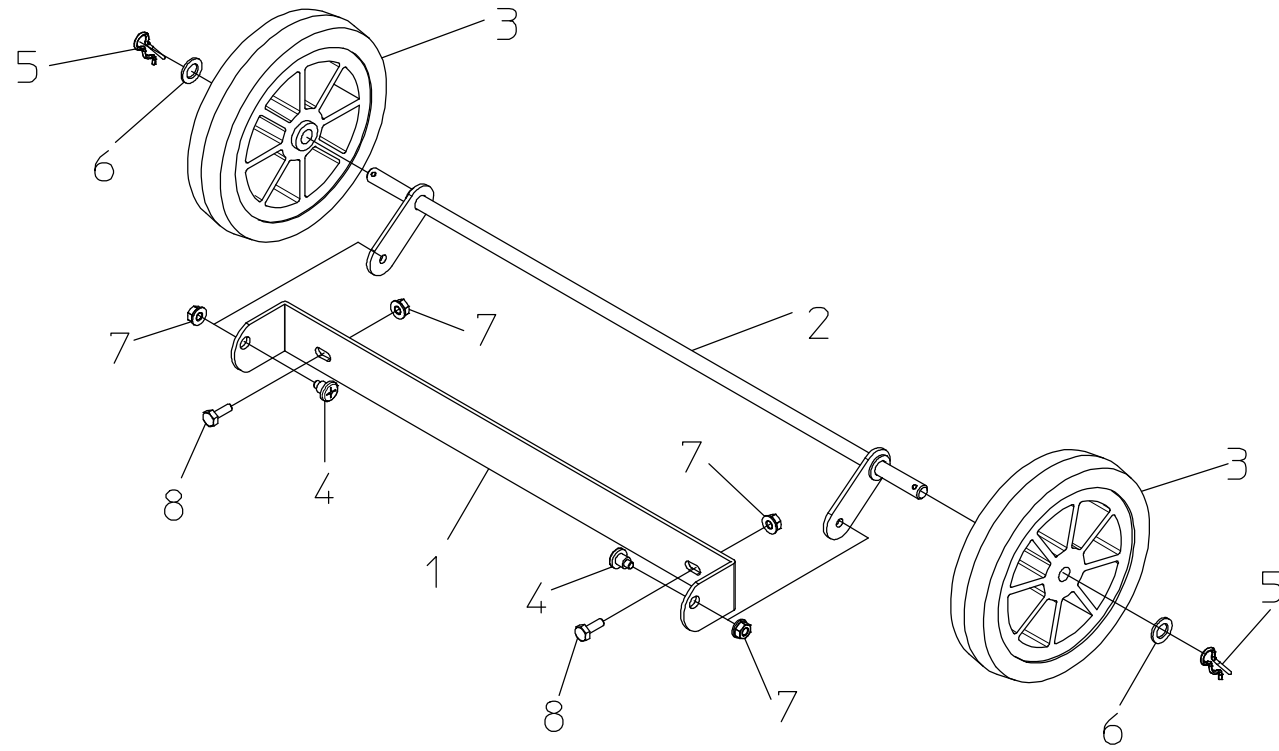

|  |  |          |  |   |
|--|--|----------|--|---|
|  |  |          |  |   |
|  |  |          |  |   |
|  |  |          |  |   |
|  |  |          |  | x |
|  |  |          |  | x |
|  |  | <b>R</b> |  |   |
|  |  |          |  |   |
|  |  |          |  |   |
|  |  |          |  | x |

その他

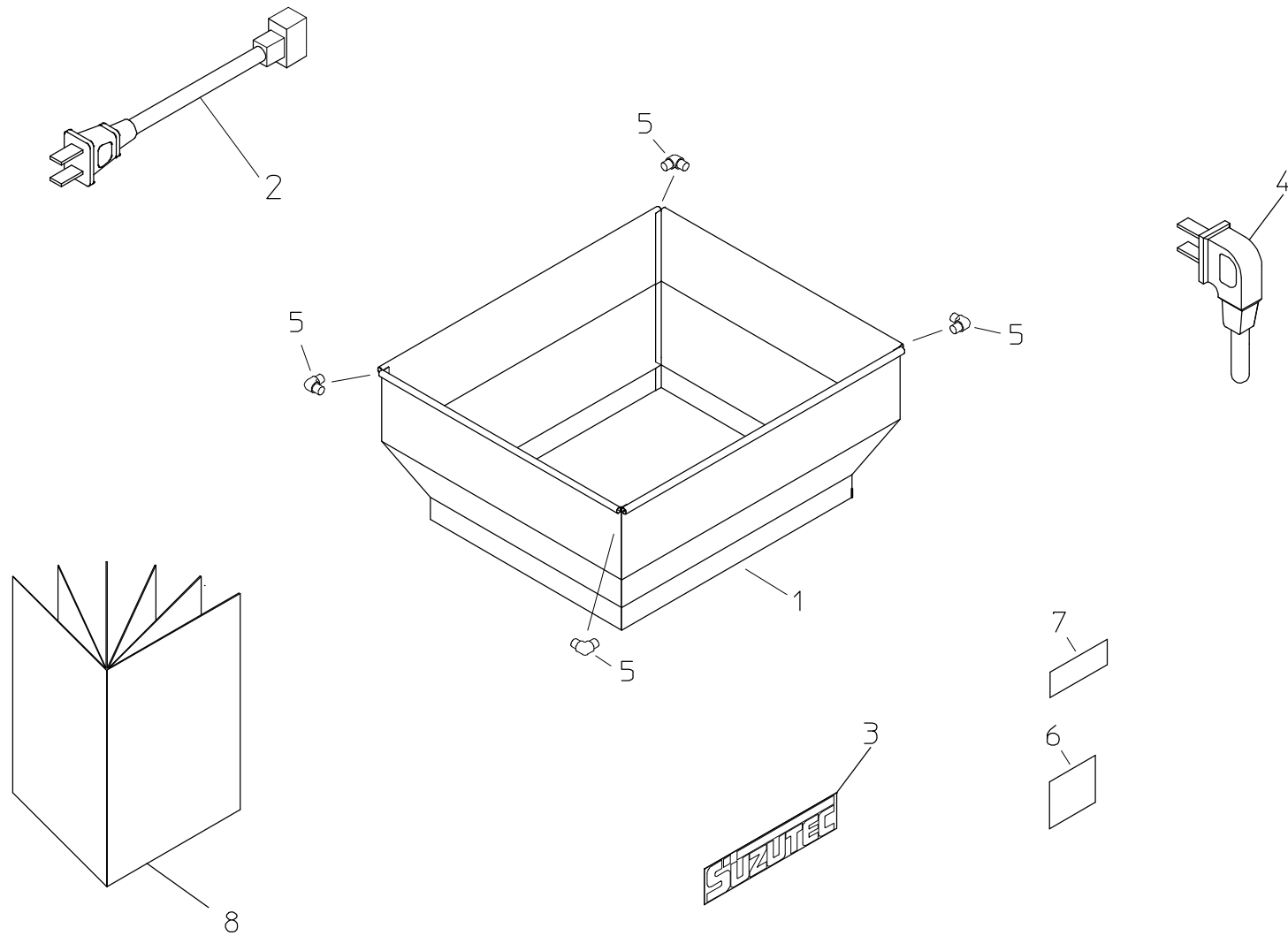

|  |  |  |  |             |
|--|--|--|--|-------------|
|  |  |  |  |             |
|  |  |  |  |             |
|  |  |  |  |             |
|  |  |  |  |             |
|  |  |  |  | <b>P nm</b> |
|  |  |  |  |             |
|  |  |  |  |             |
|  |  |  |  |             |
|  |  |  |  |             |